

PERIBEST C55 DATASHEET

TECHNICAL SPECIFICATIONS	MODEL C55
Max. Flow (continuous)	13000 l/h
Capacity	3,71l/rev
Max. Discharge Pressure	10 bar
Max. Temperature	80 °C
Inner Diameter	55 mm.
Hose material	NR, EPDM
Connections material	AISI-316, PP, PVDF (PTFE)
Pump casing material	Cast Iron Tefzel® coating

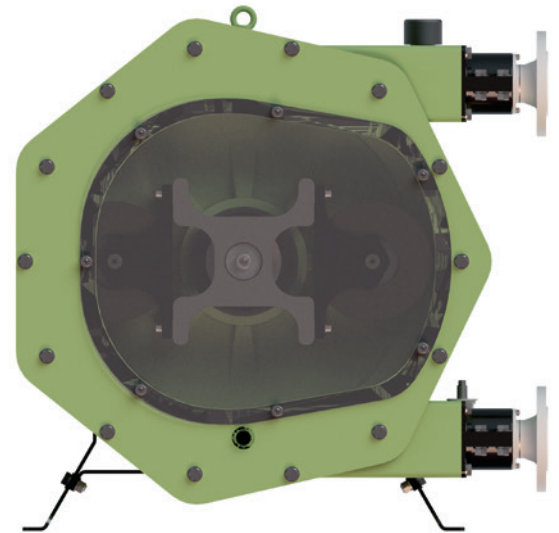

MAIN FEATURES AND BENEFITS

④

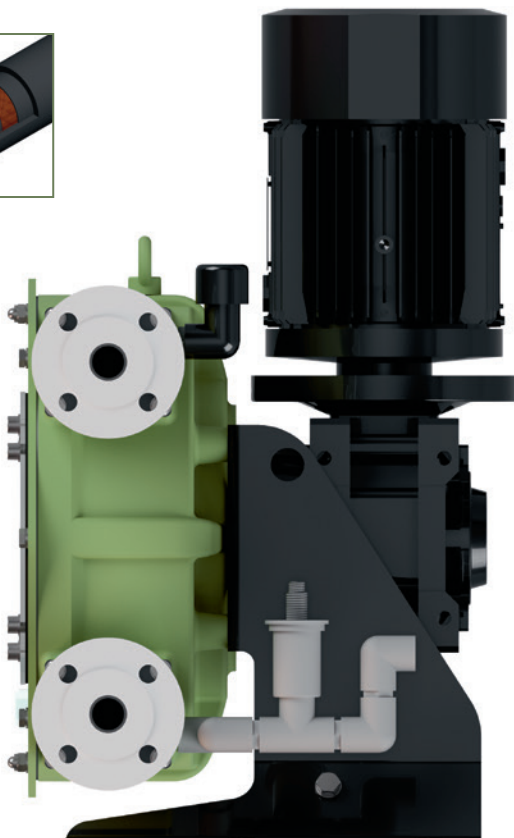

① THE BEST SOLUTION FOR DOSING AND TRANSFER ALL KIND OF ACIDS AND CORROSIVE PRODUCTS.

PUMP CASING AND FRONT COVER COATED IN TEFZEL® TOTALLY ANTICORROSIVE.

② HOSE LEAKAGE SENSOR AND DRAINAGE SYSTEM INCLUDED.

FLOAT LEVEL SENSOR, AND DRAINAGE SYSTEM TO AVOID ANY ACCUMULATION OF CORROSIVE PRODUCTS INSIDE THE PUMP CASING.

③ EXTREMELY HEAVY DUTY DESIGN FOR THE MOST DEMANDING APPLICATIONS UP TO 10 BAR.

UNMATCHED PUMP LIFE AND EXCELLENT EQUIPMENT PERFORMANCE UNDER ANY OPERATING CONDITIONS HOWEVER DEMANDING.

④ LATEST TECHNOLOGY PERISTALTIC HOSE.

SAVING ON HOSE CONSUMPTION AND EASE OF INSTALLATION DOWNTIME OPTIMISATION.

**REQUIRED
MOTOR POWER (KW)**

**PRODUCT
TEMPERATURE (°C)**

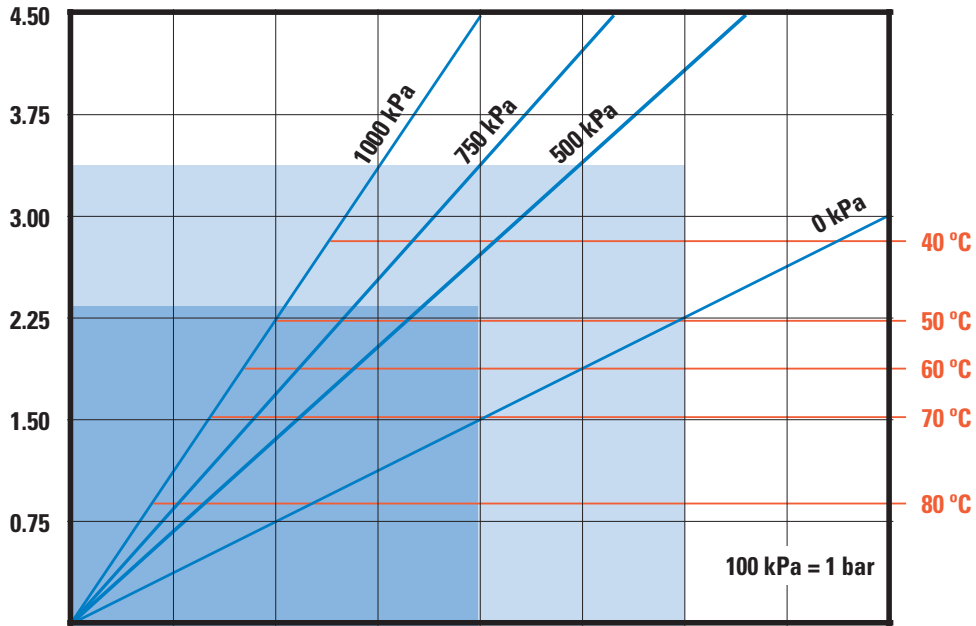

PUMP SPEED (RPM)	10	20	30	40	50	60	70	80
CAPACITY (M³/H)	2,2	4,5	6,7	8,9	11,1	13,3	15,6	17,8

PRESSURE (kPa)	0 kPa	500 kPa	750 kPa	1000 kPa
TORQUE (Nm)	360	650	810	1050

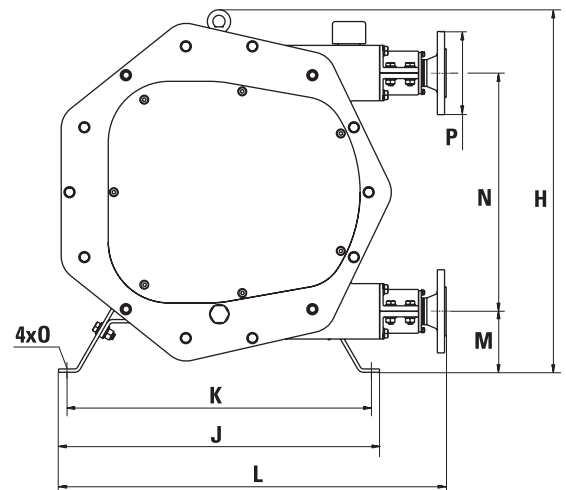
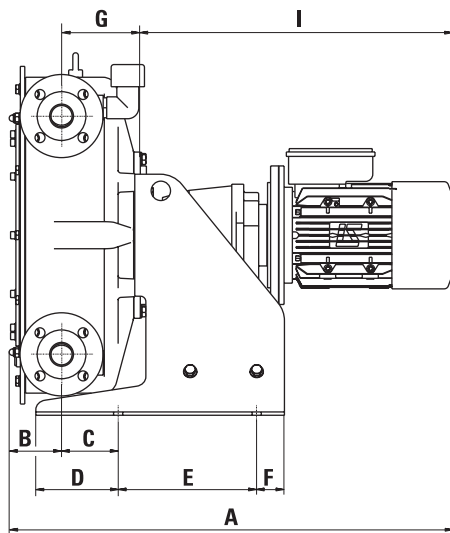

MODEL	A*	B	C	D	E	F	G	H	I*	J	K	L	M	N	O	P
C55	947,1	107	95	129	380	39,5	156,5	820	684	690	660	820	143	554	16	DN-50

*Depending on the driver, dimensions could change.