

# PERIBEST C17 DATASHEET

TECHNICAL SPECIFICATIONS	MODEL C17
Max. Flow (continuous)	500 l/h
Capacity	0,109 l/rev
Max. Discharge Pressure	10 bar
Max. Temperature	80 °C
Inner Diameter	16 mm.
Hose material	NR, EPDM & Hypalon®
Connections material	AISI-316, PP, PVDF (PTFE)
Pump casing material	Alluminium Tefzel® coating



## MAIN FEATURES AND BENEFITS

④

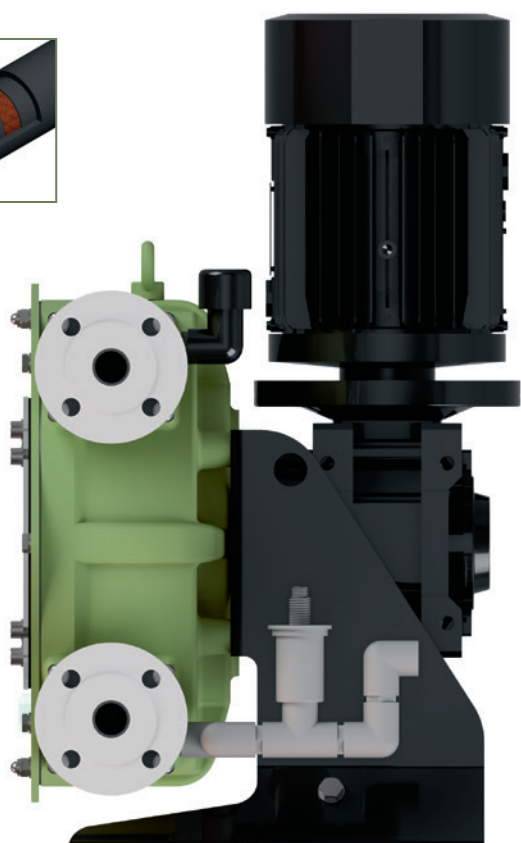

① THE BEST SOLUTION FOR DOSING AND TRANSFER ALL KIND OF ACIDS AND CORROSIVE PRODUCTS.

PUMP CASING AND FRONT COVER COATED IN TEFZEL® TOTALLY ANTICORROSIVE.

② HOSE LEAKAGE SENSOR AND DRAINAGE SYSTEM INCLUDED.

FLOAT LEVEL SENSOR, AND DRAINAGE SYSTEM TO AVOID ANY ACCUMULATION OF CORROSIVE PRODUCTS INSIDE THE PUMP CASING.

③ EXTREMELY HEAVY DUTY DESIGN FOR THE MOST DEMANDING APPLICATIONS UP TO 10 BAR.

UNMATCHED PUMP LIFE AND EXCELLENT EQUIPMENT PERFORMANCE UNDER ANY OPERATING CONDITIONS HOWEVER DEMANDING.

④ LATEST TECHNOLOGY PERISTALTIC HOSE.

SAVING ON HOSE CONSUMPTION AND EASE OF INSTALLATION DOWNTIME OPTIMISATION.

**REQUIRED  
MOTOR POWER (KW)**

**PRODUCT  
TEMPERATURE (°C)**

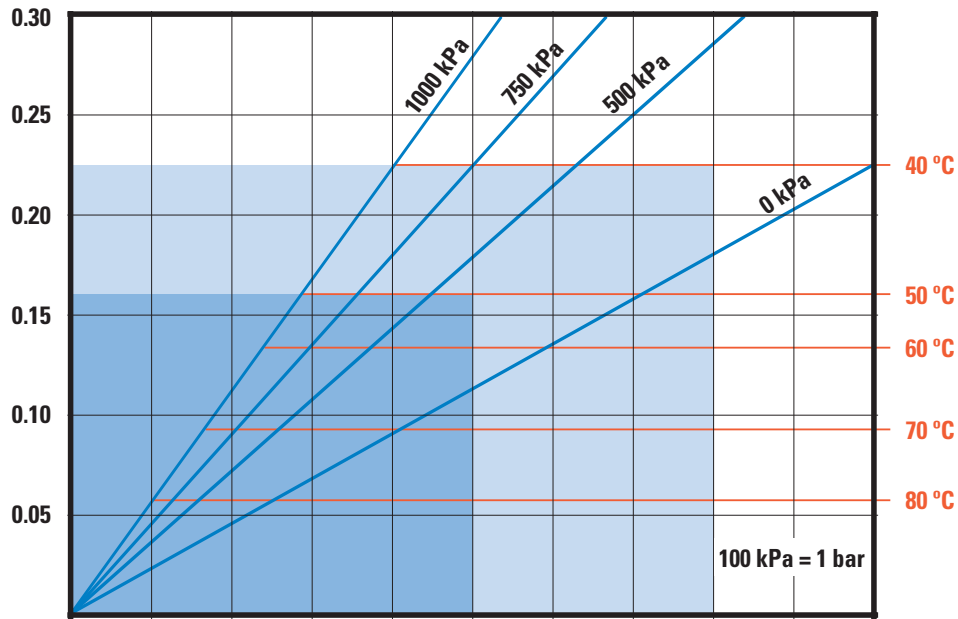

<b>PUMP SPEED (RPM)</b>	10	20	30	40	50	60	70	80	90	100
<b>CAPACITY (L/H)</b>	65	131	196	262	327	392	458	523	589	654

<b>PRESSURE (kPa)</b>	0 kPa	500 kPa	750 kPa	1000 kPa
<b>TORQUE (Nm)</b>	20	29	43	50

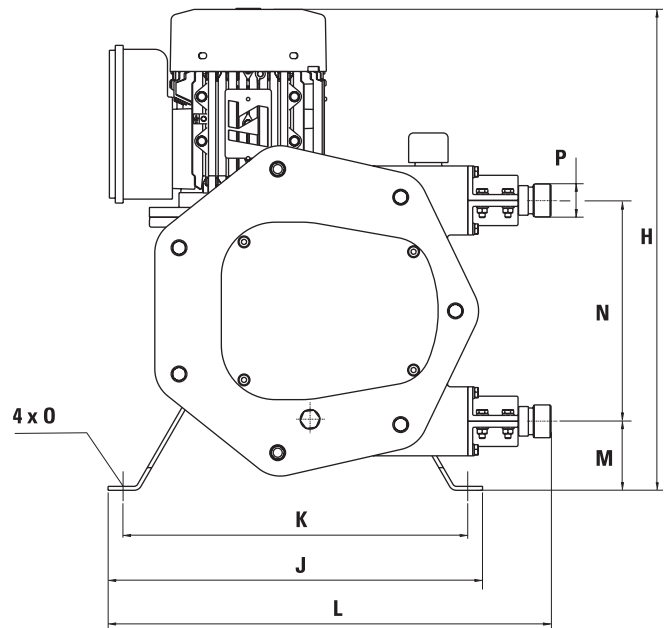
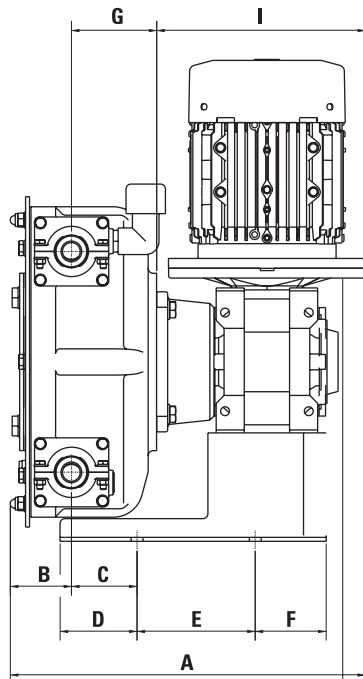

MODEL	A*	B	C	D	E	F	G	H	I*	J	K	L	M	N	O	P
<b>C17</b>	292,1	55,6	61	79,5	120	25,5	66,5	436,5	170	320	285	377,6	63	195	12	BSP 3/4"

\*Depending on the driver, dimensions could change.

[www.peribest.com](http://www.peribest.com)

Production Plant  
**PeriBest Pumps S.L.**  
 C/ Can Parellada, num. 26 Nave 10  
 Pol. Ind. Sector H  
 E-08170 Montornés del Vallés  
**Barcelona**  
 Tel. +34 935 992 214