

PERIBEST C12 DATASHEET

TECHNICAL SPECIFICATIONS	MODEL C12
Max. Flow (continuous)	205 l/h
Capacity	0,043 l/rev
Max. Discharge Pressure	10 bar
Max. Temperature	80 °C
Inner Diameter	13 mm.
Hose material	NR, EPDM & Hypalon®
Connections material	AISI-316, PP, PVDF (PTFE)
Pump casing material	Alluminium Tefzel® coating



MAIN FEATURES AND BENEFITS

④

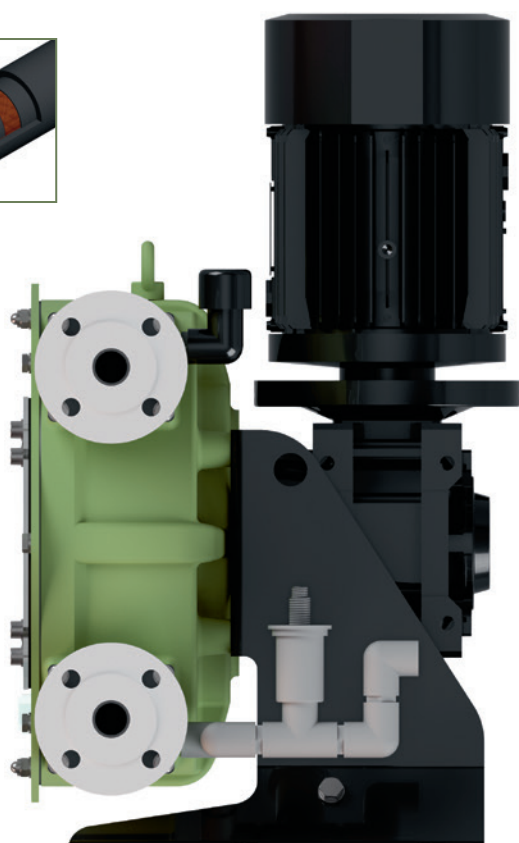

① THE BEST SOLUTION FOR DOSING AND TRANSFER ALL KIND OF ACIDS AND CORROSIVE PRODUCTS.

PUMP CASING AND FRONT COVER COATED IN TEFZEL® TOTALLY ANTICORROSIVE.

② HOSE LEAKAGE SENSOR AND DRAINAGE SYSTEM INCLUDED.

FLOAT LEVEL SENSOR, AND DRAINAGE SYSTEM TO AVOID ANY ACCUMULATION OF CORROSIVE PRODUCTS INSIDE THE PUMP CASING.

③ EXTREMELY HEAVY DUTY DESIGN FOR THE MOST DEMANDING APPLICATIONS UP TO 10 BAR.

UNMATCHED PUMP LIFE AND EXCELLENT EQUIPMENT PERFORMANCE UNDER ANY OPERATING CONDITIONS HOWEVER DEMANDING.

④ LATEST TECHNOLOGY PERISTALTIC HOSE.

SAVING ON HOSE CONSUMPTION AND EASE OF INSTALLATION DOWNTIME OPTIMISATION.

REQUIRED
MOTOR POWER (KW)

PRODUCT
TEMPERATURE (°C)

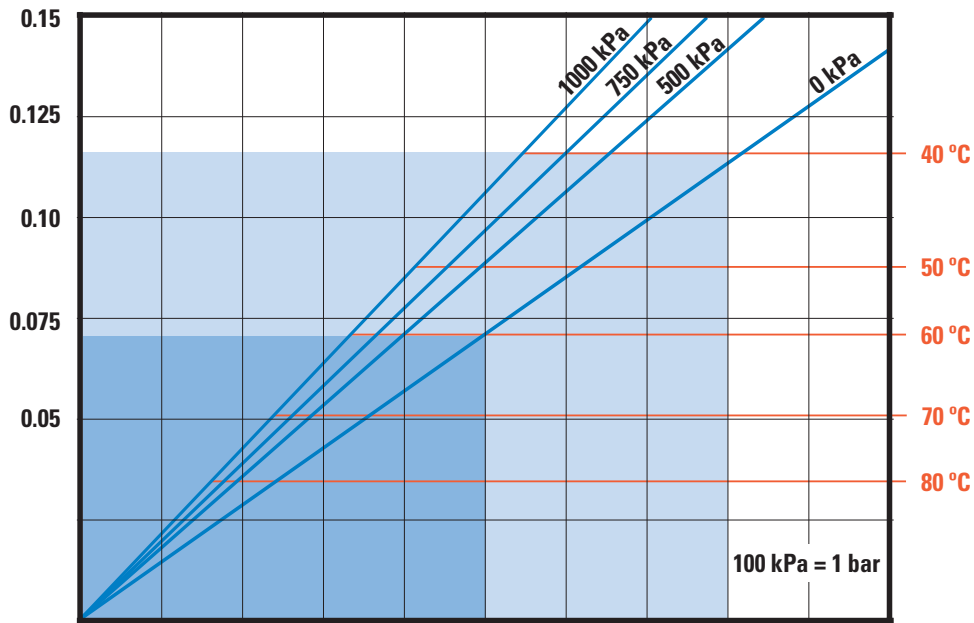

PUMP SPEED (RPM)	10	20	30	40	50	60	70	80	90	100
CAPACITY (L/H)	26	52	77	103	129	155	181	206	232	258

PRESSURE (kPa)	0 kPa	500 kPa	750 kPa	1000 kPa
TORQUE (Nm)	14	17	19	22

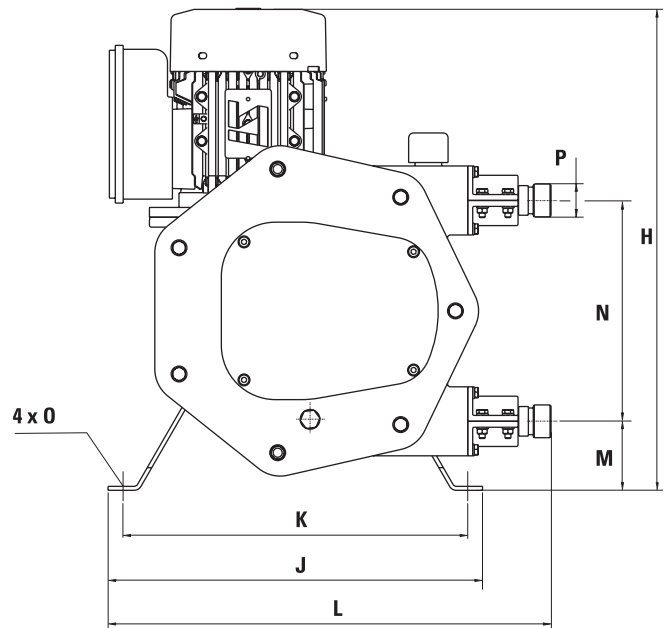
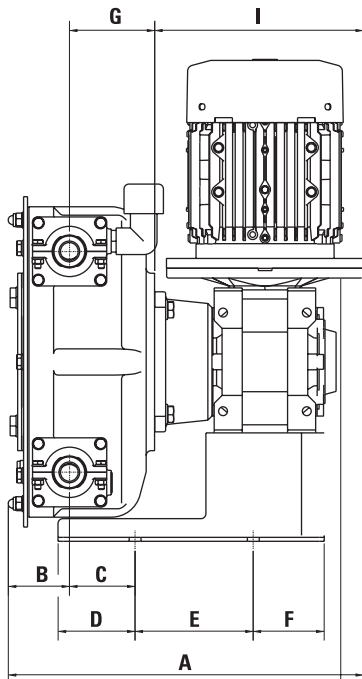

MODEL	A*	B	C	D	E	F	G	H	I*	J	K	L	M	N	O	P
C12	240,3	47,5	50	54,3	80	32,8	55,8	367	137	265	235	305	62	116	12	BSP 3/8"

*Depending on the driver, dimensions could change.