

PERIBEST T05 DATASHEET

TECHNICAL SPECIFICATIONS	MODEL T05
Max. Flow (continuous)	25 l/h
Capacity	0,0042 l/rev
Max. Discharge Pressure	10 bar
Max. Temperature	80 °C
Inner Diameter	5 mm
Hose material	TPV, PVC
Connections material	PP, S.S.
Pump casing material	Polethylene HD (high density)
Roller material	Polyamide 6 (Nylon)
Tube leakage sensor	Included (12-36VDC, PNP, NO)

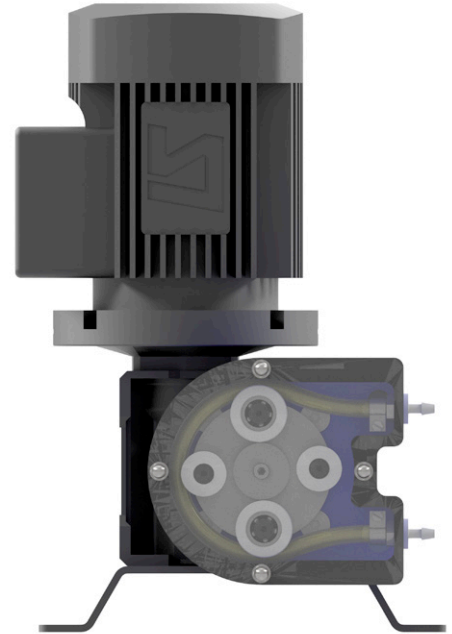

MAIN FEATURES AND BENEFITS

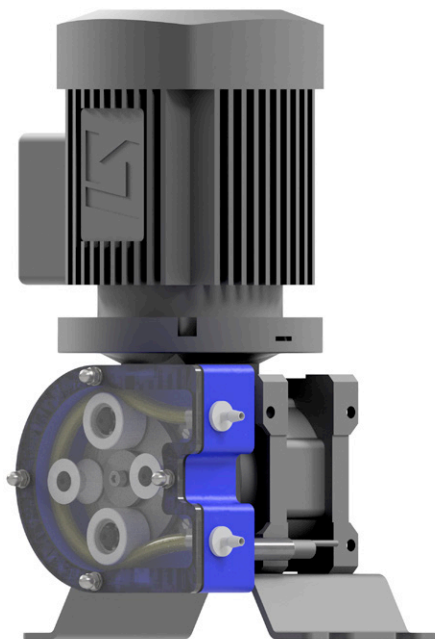

1 HEAVY DUTY TUBING PUMP.

INDUSTRIAL DRIVER 24/7 DESIGN WITH BIG ROLLERS AND INTEGRATED BEARINGS. WORKING PRESSURE UP TO 4 BAR.

2 COMPETITIVE SOLUTION.

HIGH QUALITY PUMP AT A VERY COMPETITIVE PRICE LEVEL. EXCELLENT SOLUTION FOR HIGH SUCTION, OFFGASES PRODUCTS, HIGH SOLID CONTENT, AND VISCOUS PRODUCTS.

3 SAFE PUMP: HERMETIC SEALING.

TOTAL HERMETIC PUMP WITH MINIMUM RISK OF EXPENSIVE LEAKS TYPICAL FROM OTHER TUBING PUMPS. ANTICORROSIVE CONSTRUCTION MATERIALS AND TUBE RUPTURE SENSOR INCLUDED.

4 LOW OPERATING EXPENSES.

VERY LOW MAINTENANCE COST AND EASY TUBE EXCHANGE THANKS TO ROTOR DESIGN WITH TWO ROLLER GUIDES, SPECIALLY DESIGNED FOR EASY TUBE REPLACEMENT.

CAPACITY (L/H)

PRODUCT TEMPERATURE (°C)

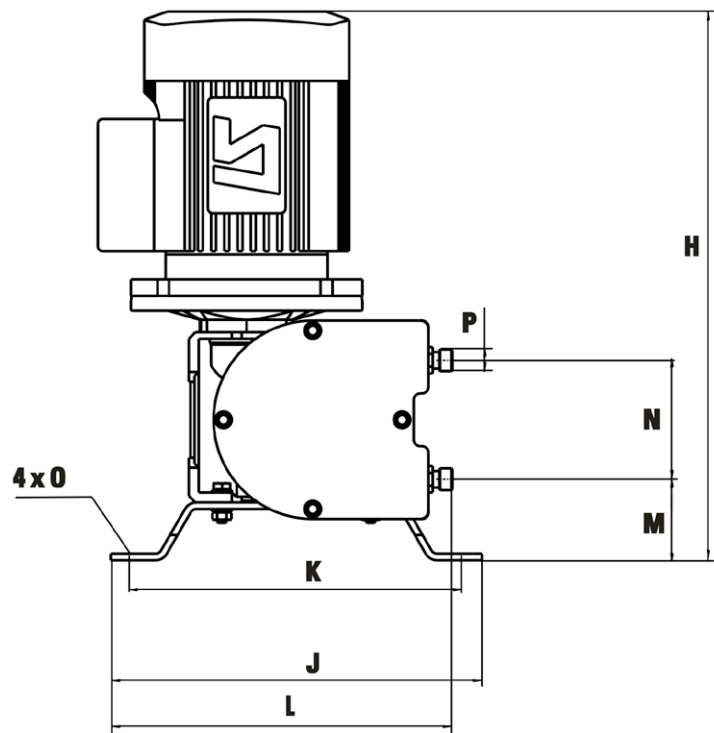
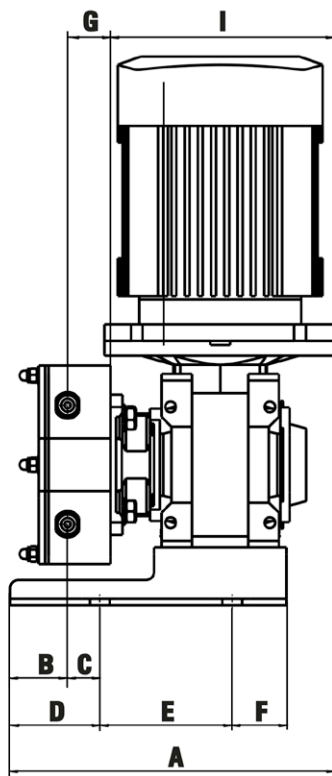
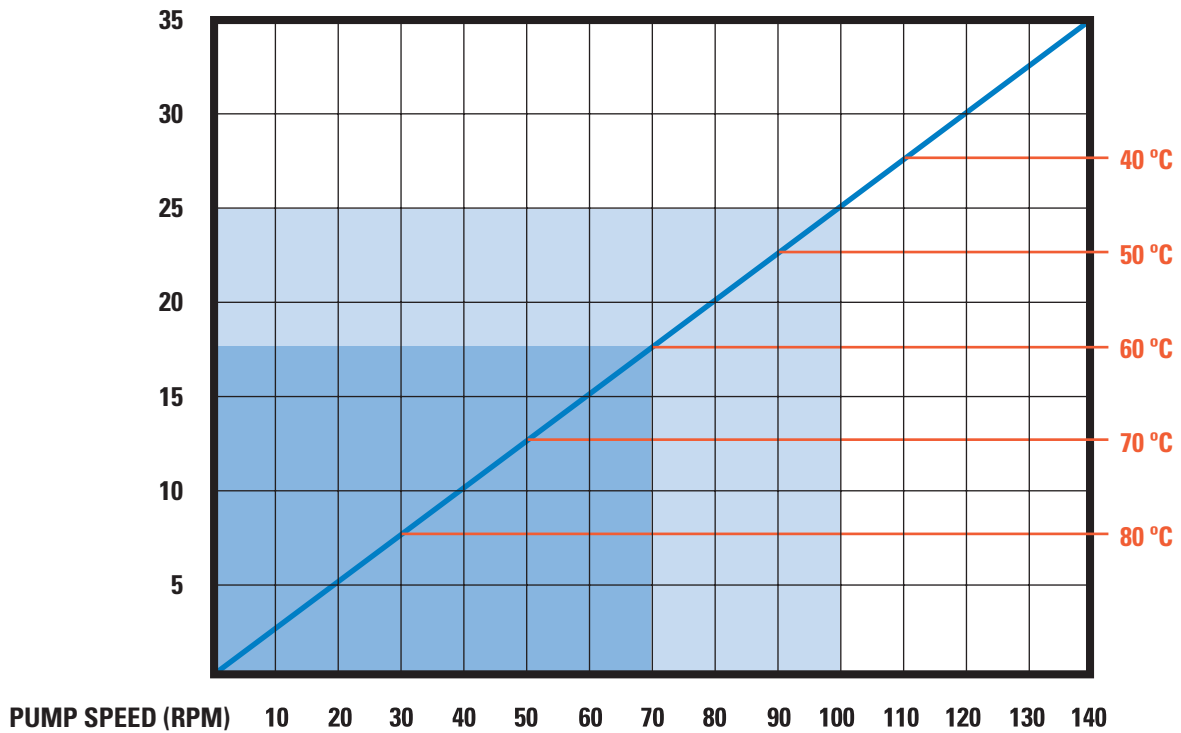

MODEL	A*	B	C	D	E	F	G	H	I*	J	K	L	M	N	O	P
T05	191,5	28,5	68	96,5	50	25	26	332	137	215	195	209	52	66	12	Barb 5 mm

*Depending on the driver, dimensions could change.

www.peribest.com

Production Plant
PeriBest Pumps S.L.
 C/ Can Parellada, num. 26 Nave 10
 Pol. Ind. Sector H
 E-08170 Montornés del Vallés
Barcelona
 Tel. +34 935 992 214